

TOWN OF SOMERS

SOMERS SENIOR/COMMUNITY CENTER



January 2023



AGENDA

1. Introduction/Welcome/Overview
2. Why a new Senior/Community Center?
3. Project Timeline
4. Survey Results
5. Proposed Building Program
6. Site Selection
7. Conceptual Design – Plans & Renderings
8. Questions & Answers



PRELIMINARY LONG-TERM PROJECT SCHEDULE

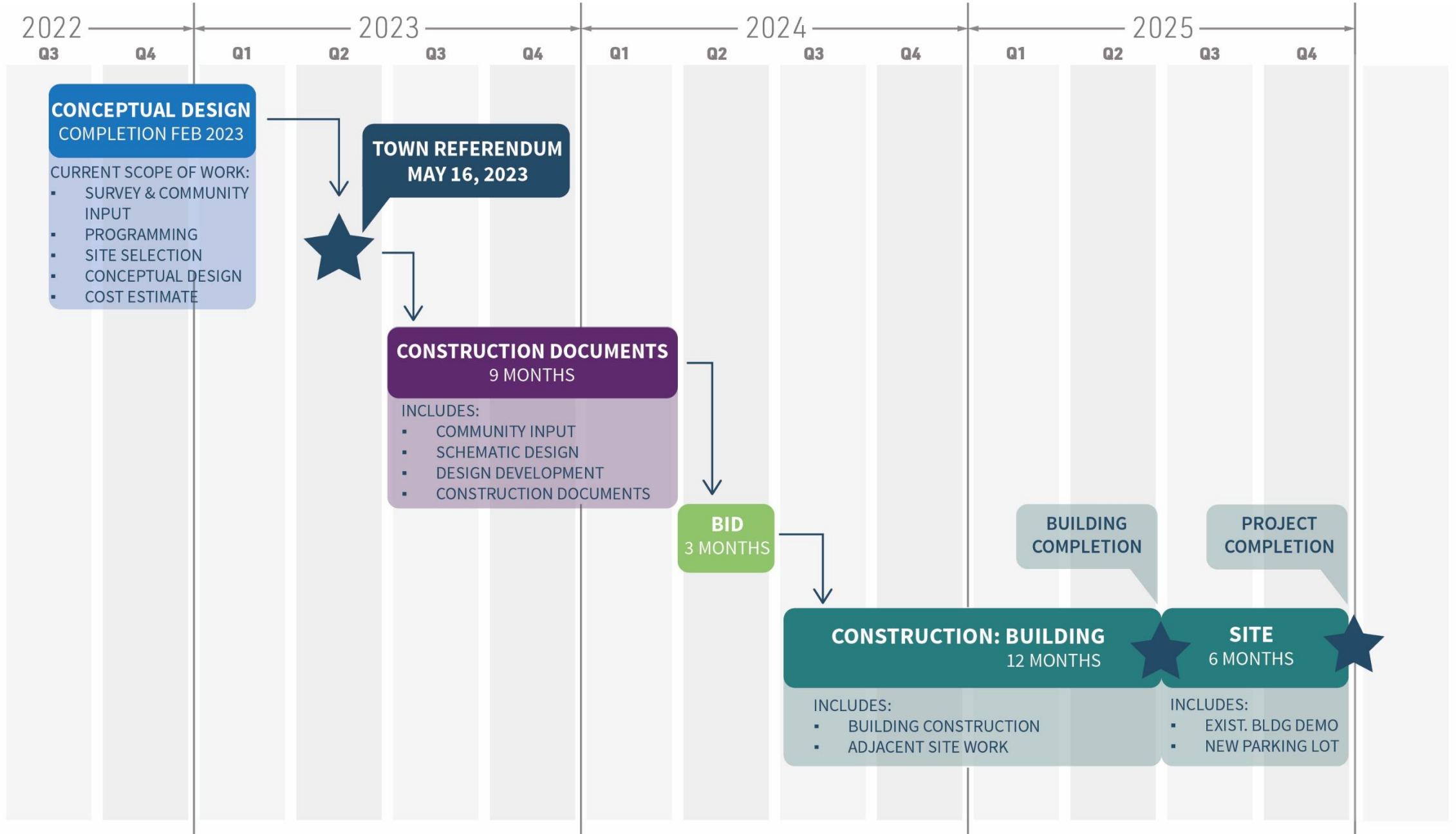

PRELIMINARY LONG-TERM PROJECT SCHEDULE – COMMUNITY INPUT

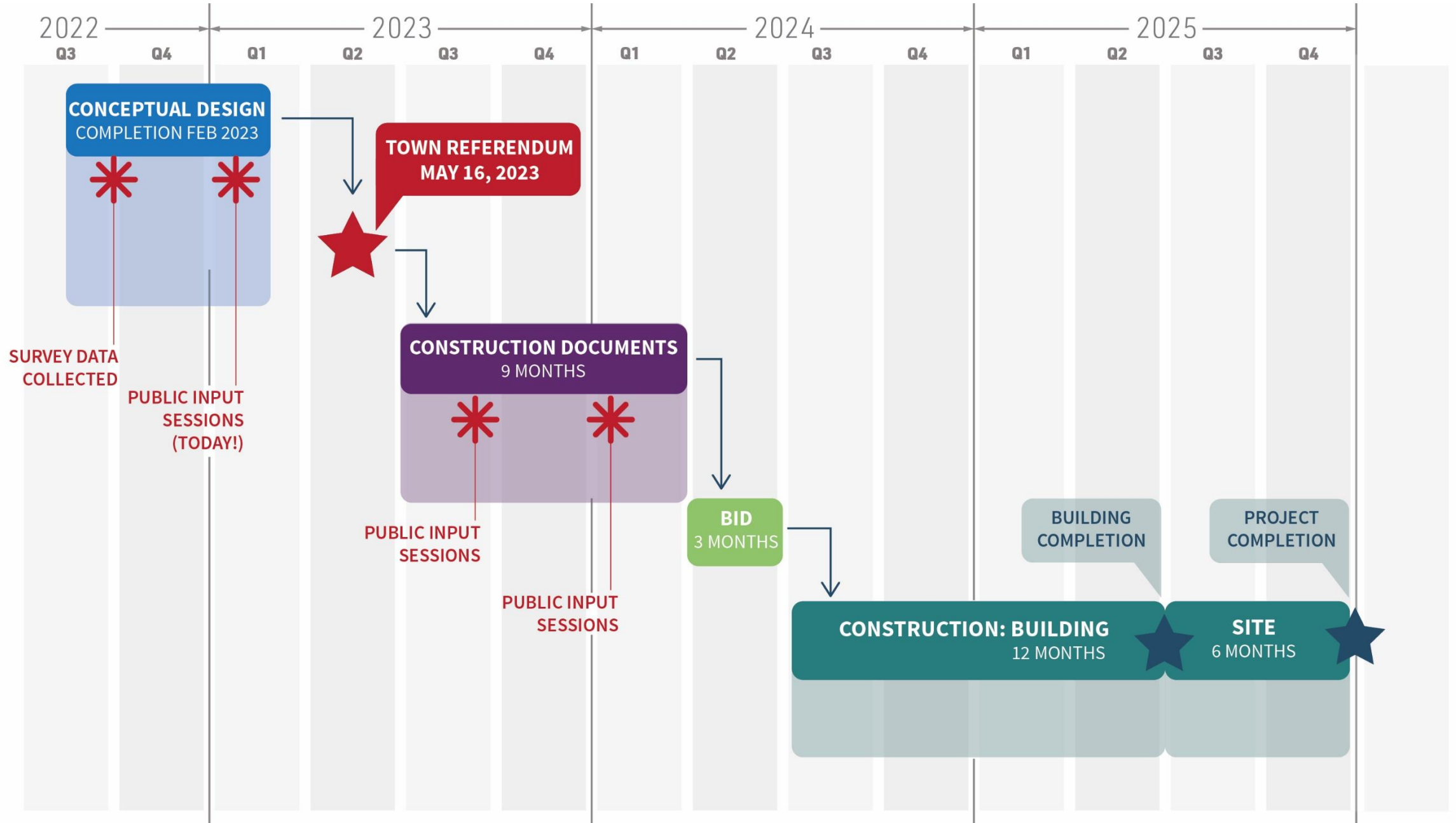

SURVEY RESULTS

Survey was mailed to all residents of the town of Somers in late September.
723 total responses were collected

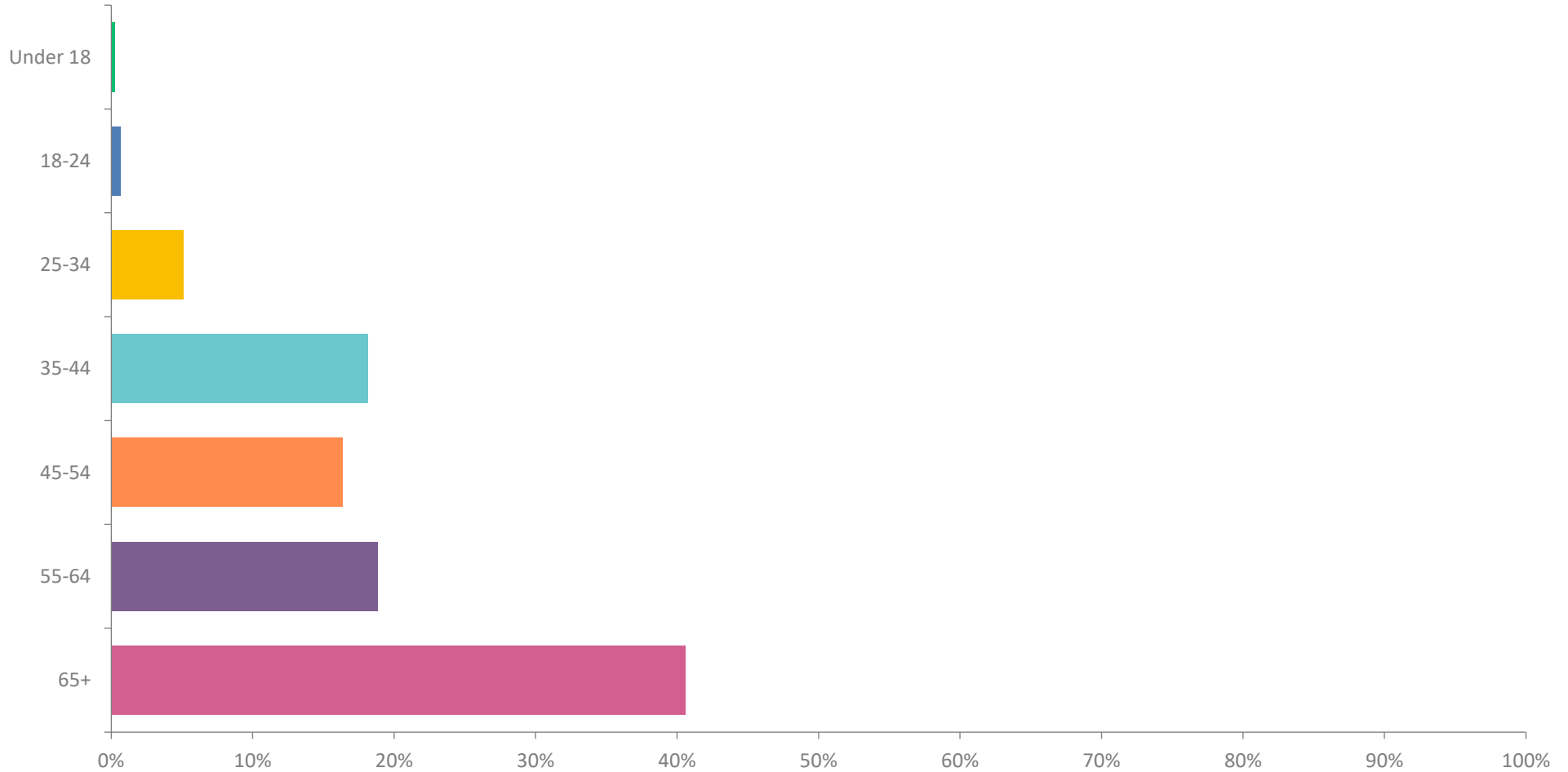

SURVEY RESULTS

What type of recreation/community space would you like to see in the future Somers Senior/Community Center? Please select up to three (3).

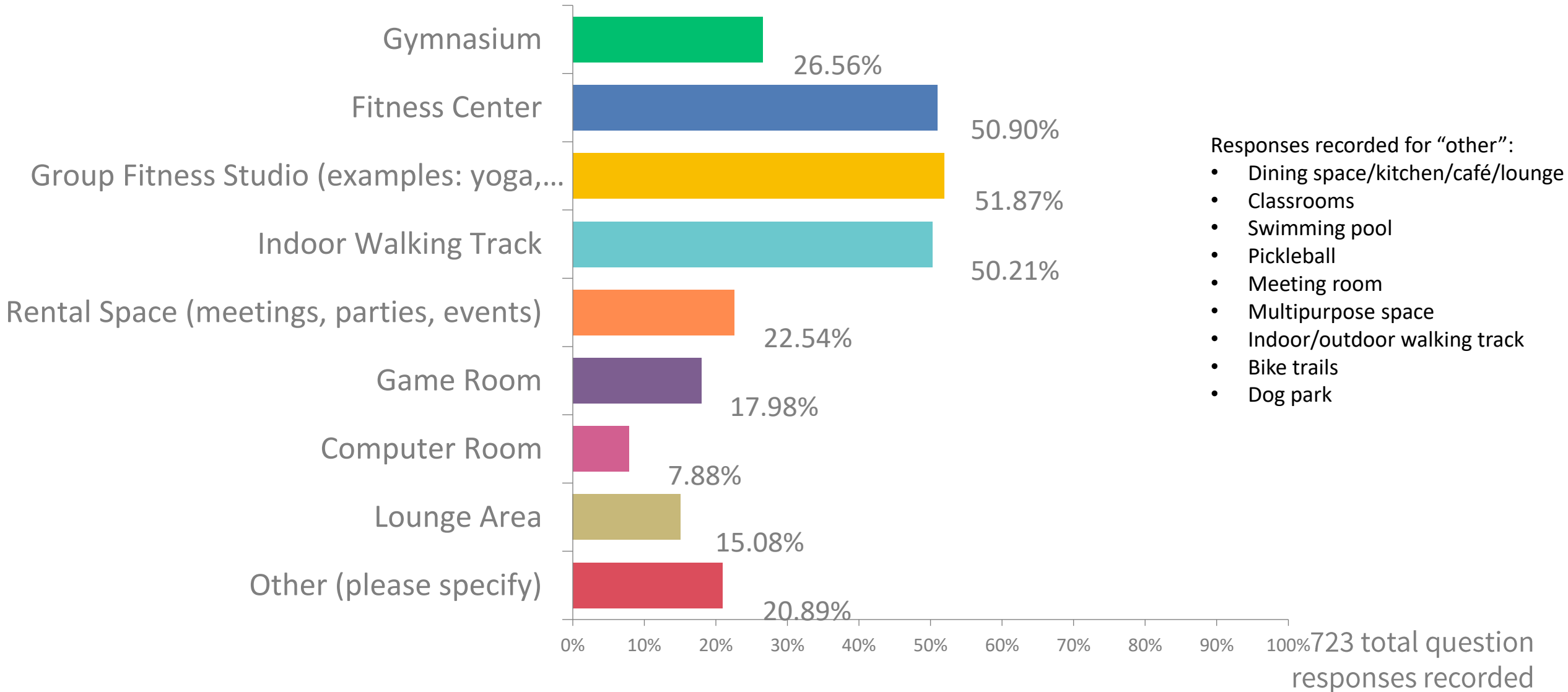

SURVEY RESULTS

Which activities would you be most interested in participating in at the future Somers Senior/Community Center? Please select up to three (3).

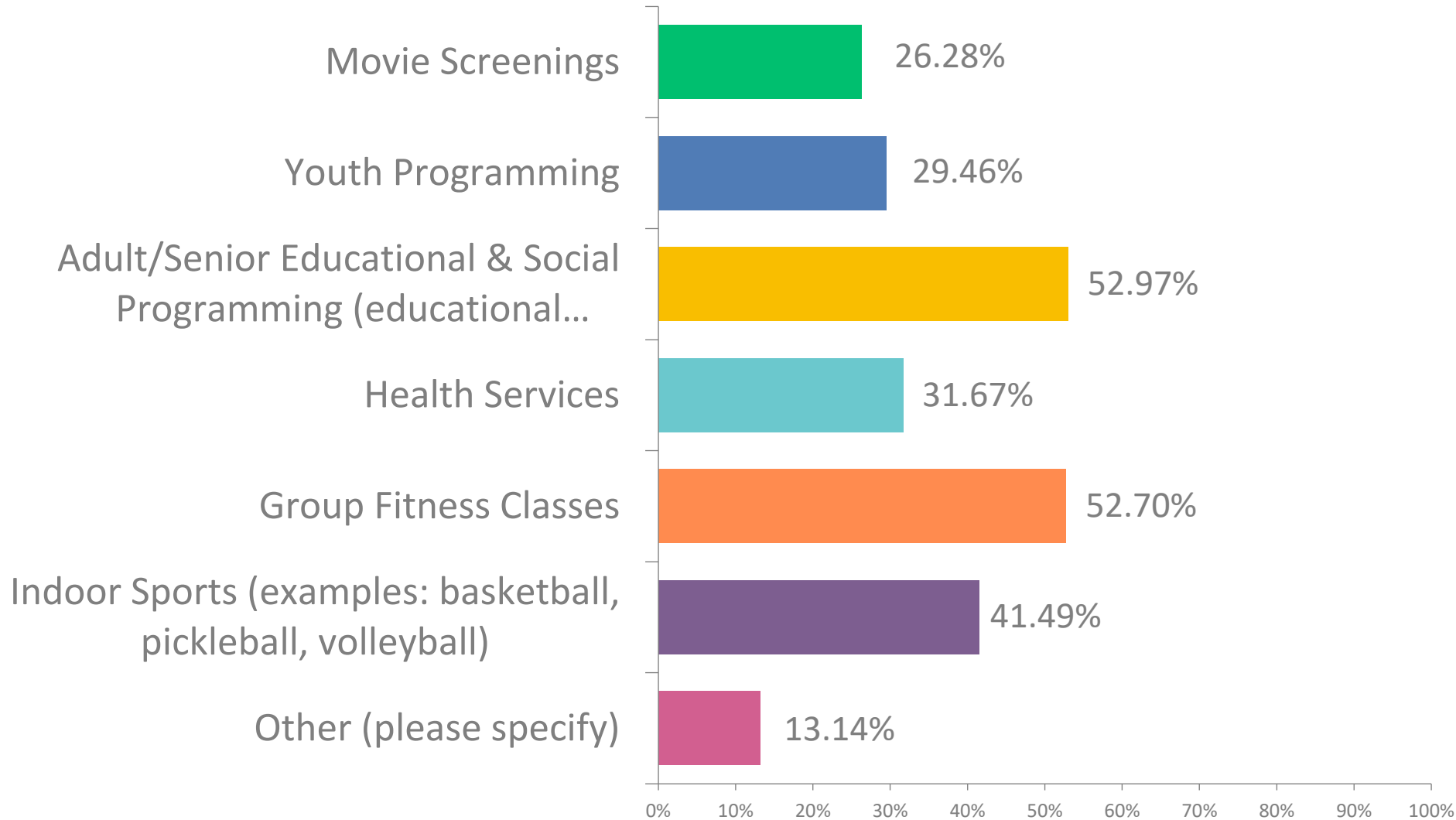

Responses recorded for "other":

- Bus trips
- Swimming pool
- Pickleball court
- Entertainment
- Craft and farmer markets
- Indoor/outdoor walking track
- Concerts and events
- Youth programming
- Personal training

723 total question responses recorded

SURVEY RESULTS

The future Somers Senior/Community will be a success if...

“we listen to **everyone's needs**, not just the loudest. Also, keep younger adults and new families in mind - we want to attract and retain them for a **strong town future.**”

“if you provide spaces and activities for **all ages.**”

“it has **good communication** and effective management.”

“it has activities that will benefit the **entire community.**”

“it **did not raise taxes.**”

“it is built to accommodate the growing number of **seniors** in Somers, and with future needs taken into consideration.”

“there is **consistent communication** to the community.”

“the community is able to provide continued input and the space is used to the fullest capacity. As well as a **wide availability of hours** to use the facility.”

438 total question responses recorded

■ not supportive ■ supportive/constructive comment

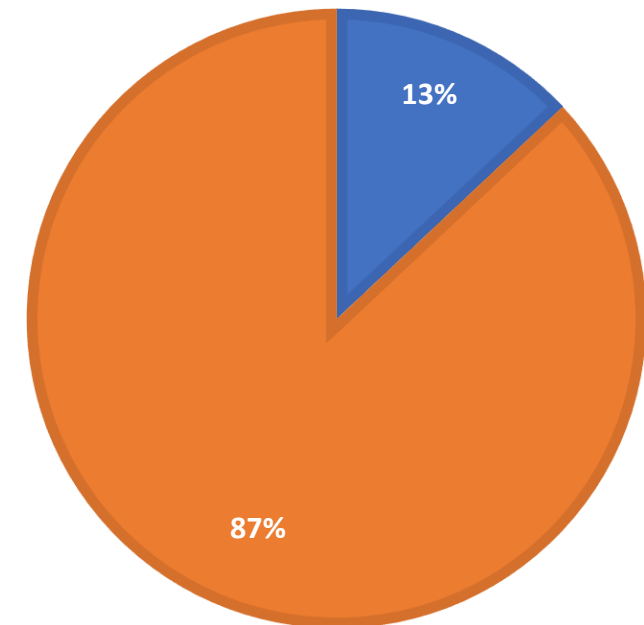

SURVEY RESULTS

Most requested spaces:

1. Group fitness studio
2. Fitness center
3. Indoor walking track
4. Gymnasium
5. Rental space (meetings, parties, events)

Most requested activities:

- A. Adult/Senior educational & social programming
(educational presentations, luncheons, arts & crafts, bingo)
- B. Group fitness classes
- C. Indoor sports (basketball, pickleball, volleyball)
- D. Health services
- E. Youth programming
- F. Movie screenings

SURVEY RESULTS

Most requested spaces:

1. Group fitness studio
 - B. Group fitness classes
2. Fitness center
3. Indoor walking track
4. Gymnasium
 - C. Indoor sports (basketball, pickleball, volleyball)
 - E. Youth programming
5. Rental space (meetings, parties, events)
 - A. Adult/Senior educational & social programming
(educational presentations, luncheons, arts & crafts, bingo)
 - F. Movie screenings

Most requested activities:

- D. Health services

PROGRAMMING

RECREATION & ACTIVITY

WALKING TRACK
2,400 SF

GYMNASIUM
3,000 SF

Accommodates:
Youth size basketball cross court (1) (58'x42')
Volleyball court
Pickelball courts (2)
Large events
Fitness programming (yoga, strength, etc.)

FITNESS STUDIO
1,000 SF

Accommodates:
Yoga / Stretching
Aerobics / Cardio
Strength training, Free weights
Dance / Kids play

PUBLIC

RECEPT. DESK
200 SF

LOBBY
800 SF
Accommodates:
Waiting / Pre-function
Lounge/ Gathering
Coffee, Fireplace

COMMUNITY

CATERING KITCHEN
300 SF

MULTIPURPOSE
1,700 SF

Accommodates:
100p @ tables & chairs
200+p lecture/standing
Large group events
Lunches, Movies, Bingo

CLASSROOM
700 SF

Accommodates:
35p @ tables & chairs
Senior Programming
Meetings, Cards,
Games, Arts & Crafts

HEALTH/ MEETING
150 SF
Counseling,
Foot care

PROGRAMMING

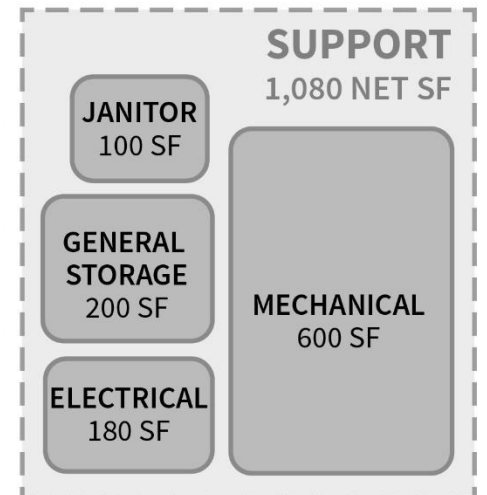
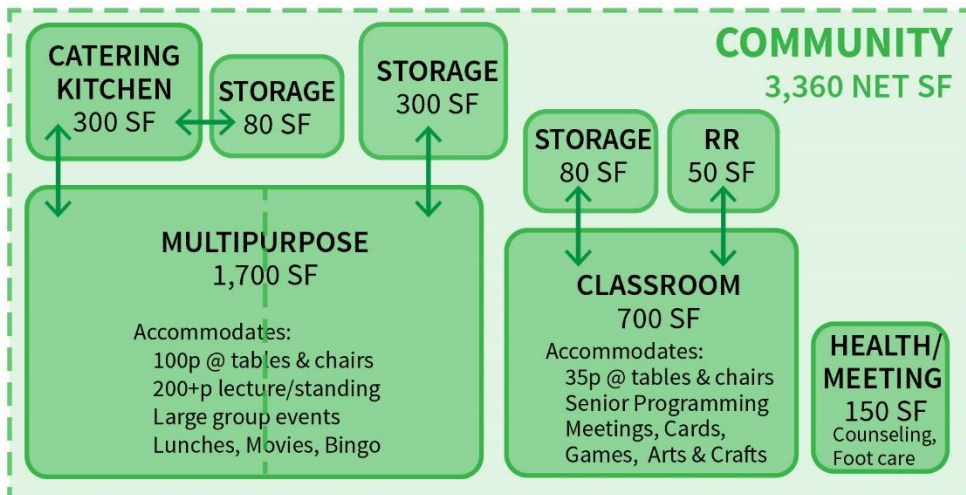
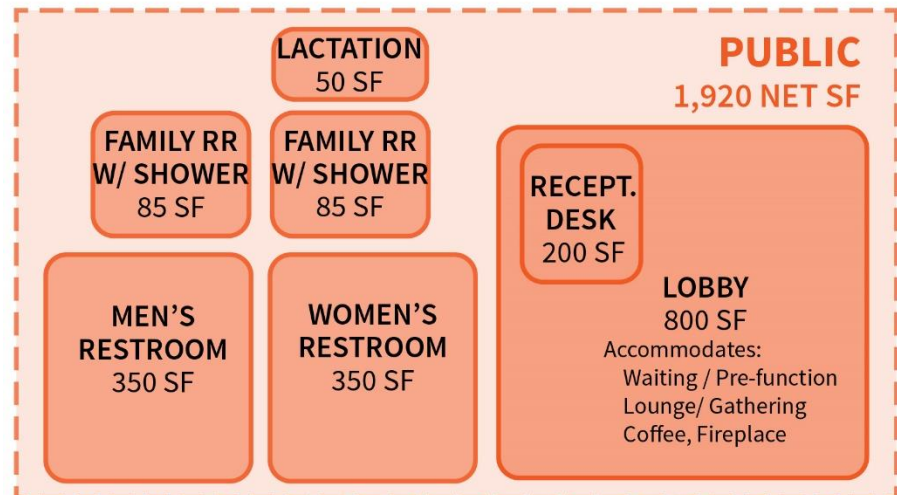
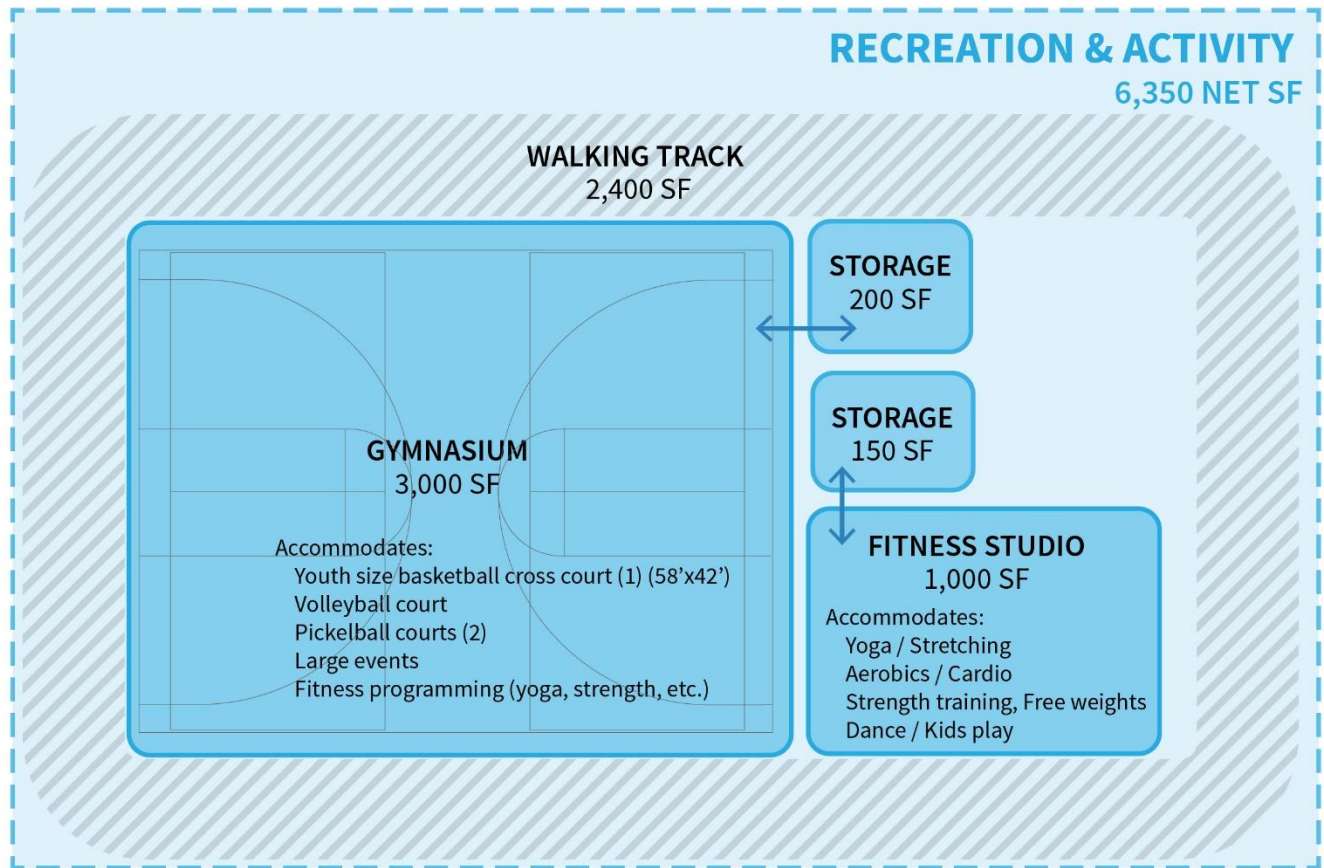
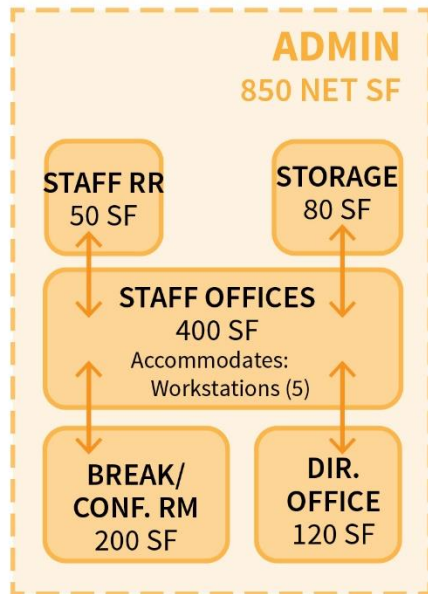
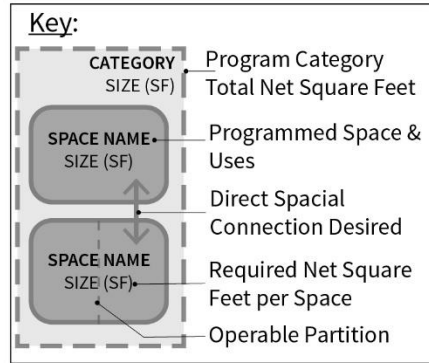

PROGRAMMING

PROPOSED SIZE: 13,560 NET SQUARE FEET

+ GROSSING FACTOR 20%

TOTAL BUILDING: 16,272 GROSS SQUARE FEET

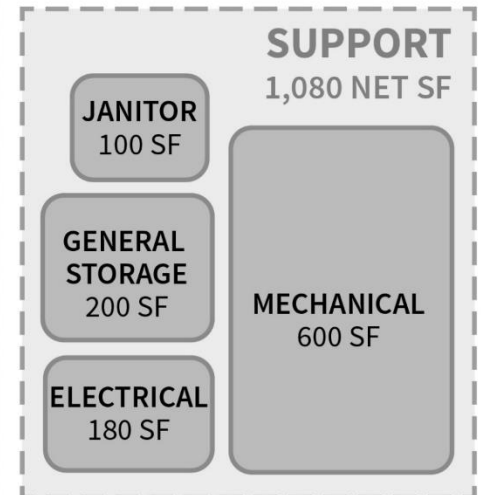
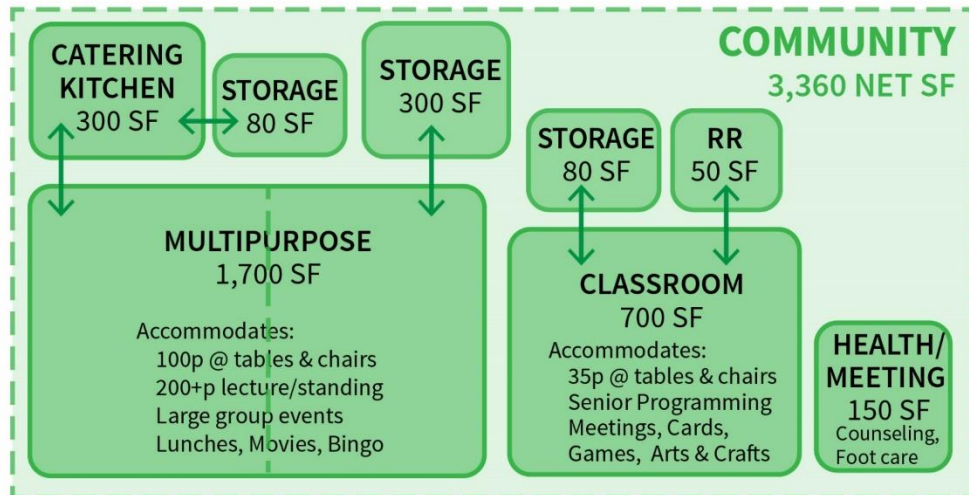
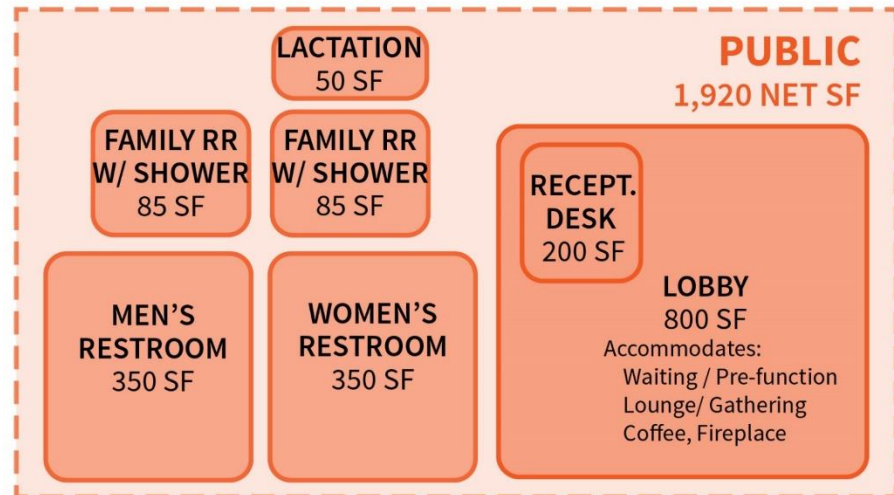
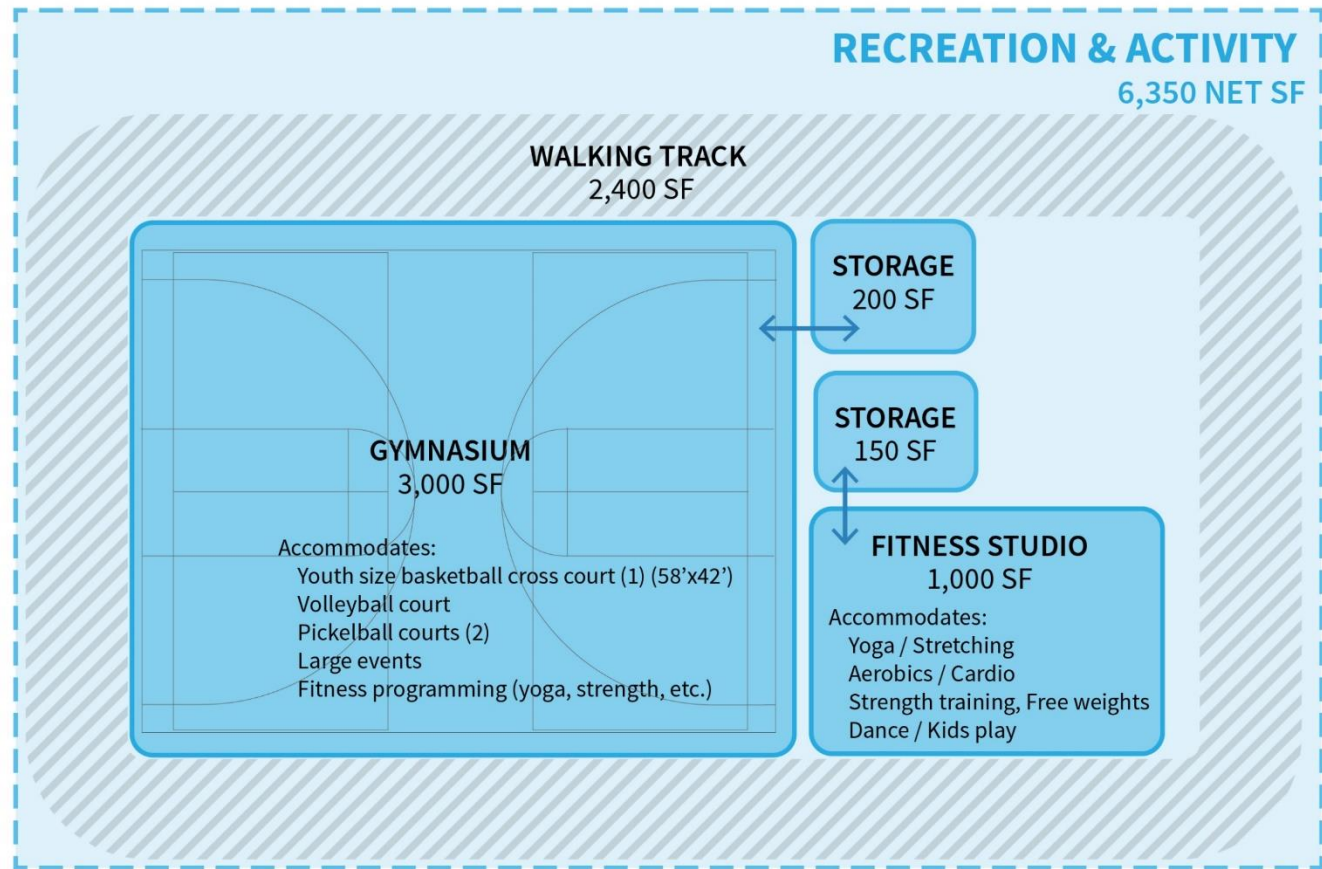
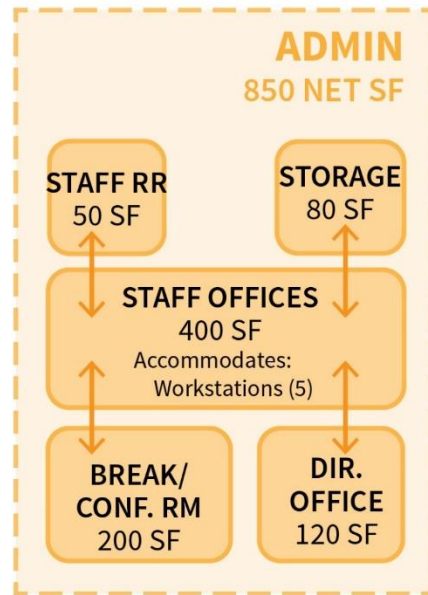
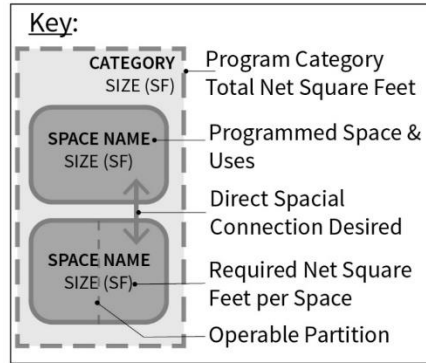

SITE SELECTION

600 MAIN STREET TOWN HALL SITE



- Floodplain
- Limited access
- Limited parking

619 MAIN STREET KIBBE FULLER ADDITION/RENOVATION



- Kibbe Fuller is fully occupied
- Renovation would be costly
- Split level creates an accessibility challenge
- Limited space between Kibbe Fuller building and the Museum

19 BATTLE STREET NEW CONSTRUCTION



- Ample space available
- Ability to incorporate outdoor program spaces
- Ability to expand parking easily
- Creates a campus feeling with Kibbe Fuller and the Museum

PROPOSED SITE PLAN

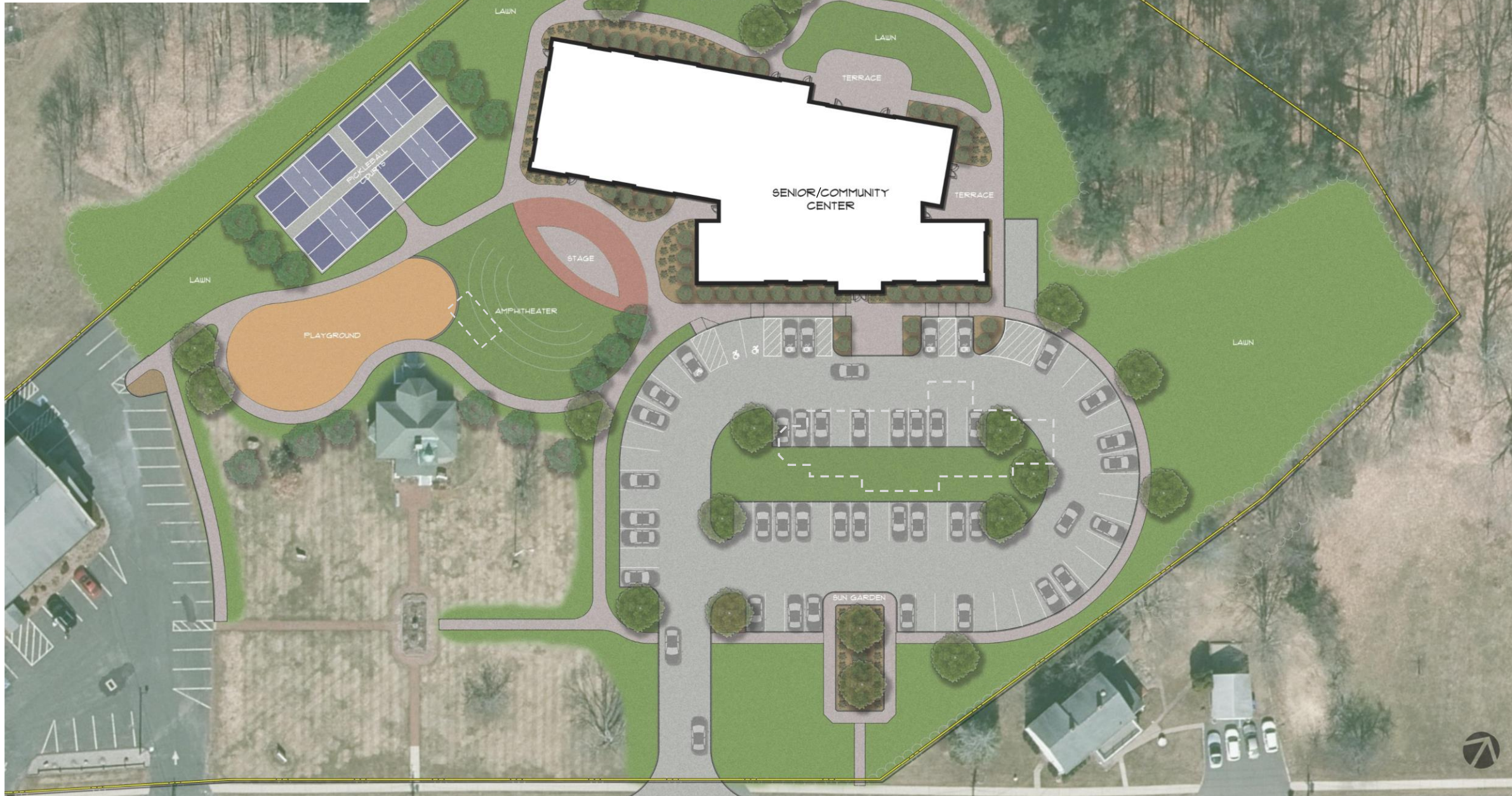

BATTLE STREET

BATTLE STREET

BATTLE STREET

PROPOSED FLOOR PLAN

TOTAL AREA = 15,465 GSF

- KEY:**
- RECREATION & ACTIVITY
 - COMMUNITY
 - PUBLIC
 - ADMINISTRATION
 - SUPPORT

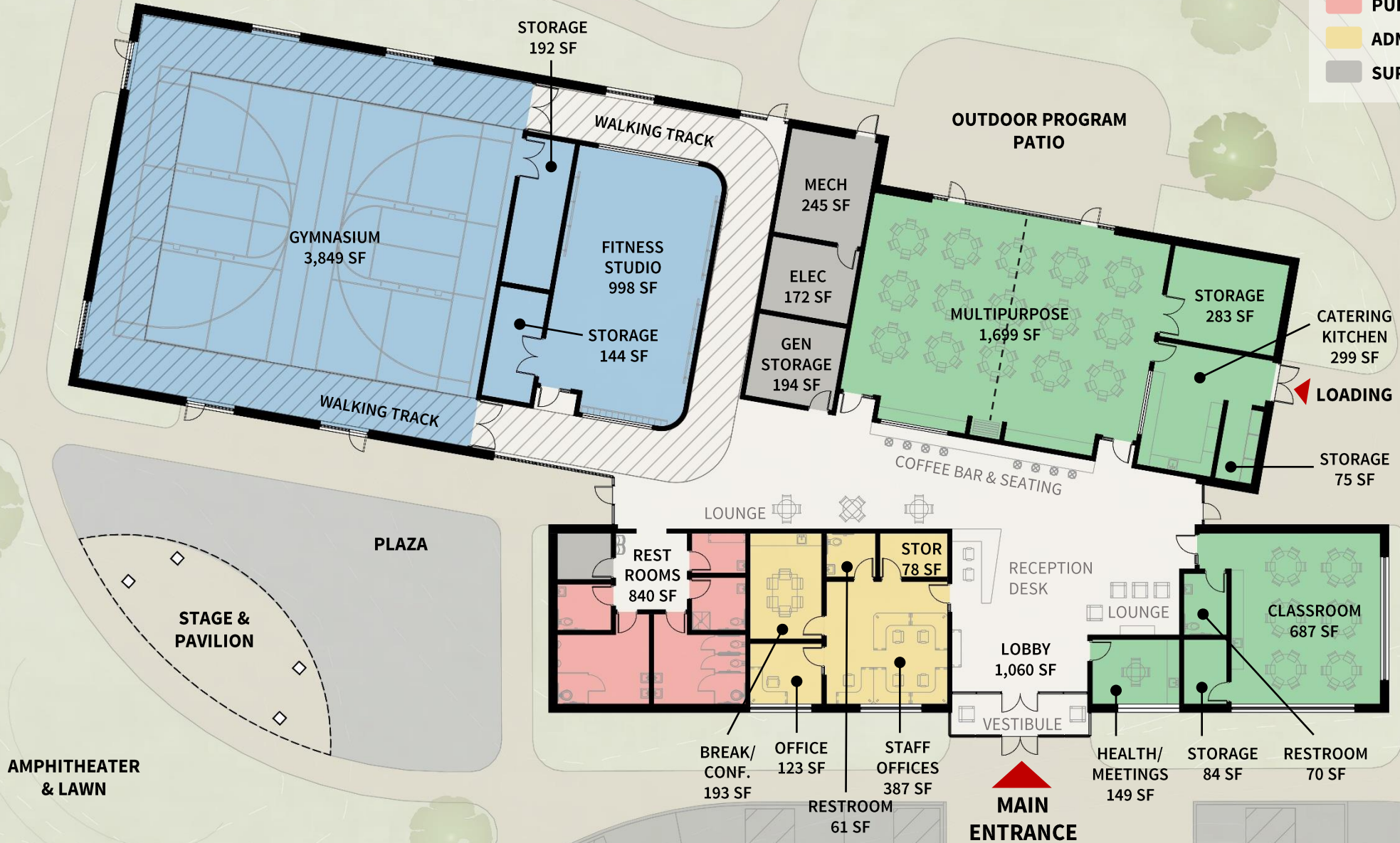

SITE CONTEXT: HISTORICAL MUSEUM & KIBBE FULLER



SITE CONTEXT: HISTORICAL MUSEUM & KIBBE FULLER



SITE CONTEXT: HISTORICAL MUSEUM & KIBBE FULLER

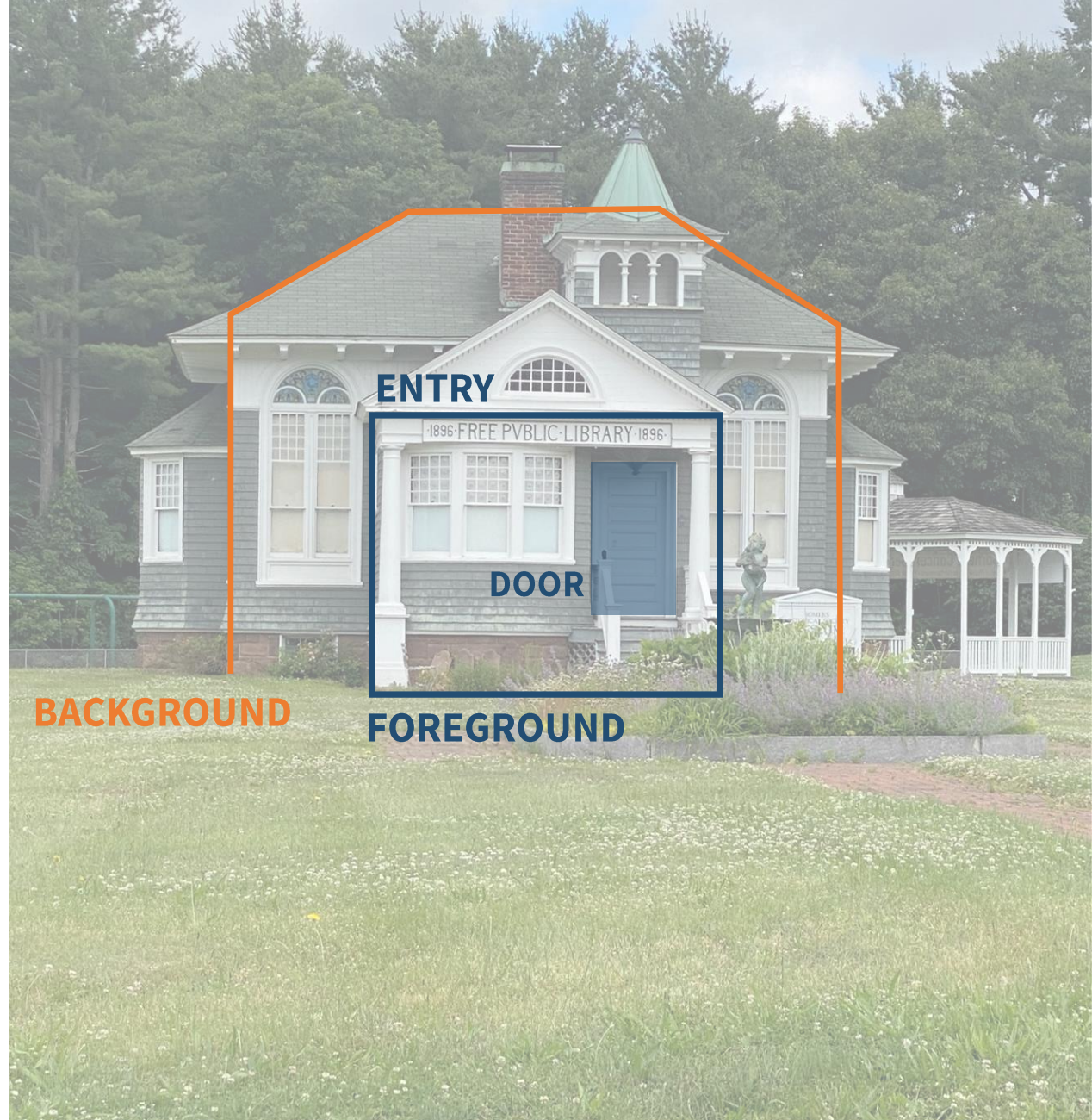

SITE CONTEXT: HISTORICAL MUSEUM & KIBBE FULLER



SITE CONTEXT: HISTORICAL MUSEUM & KIBBE FULLER

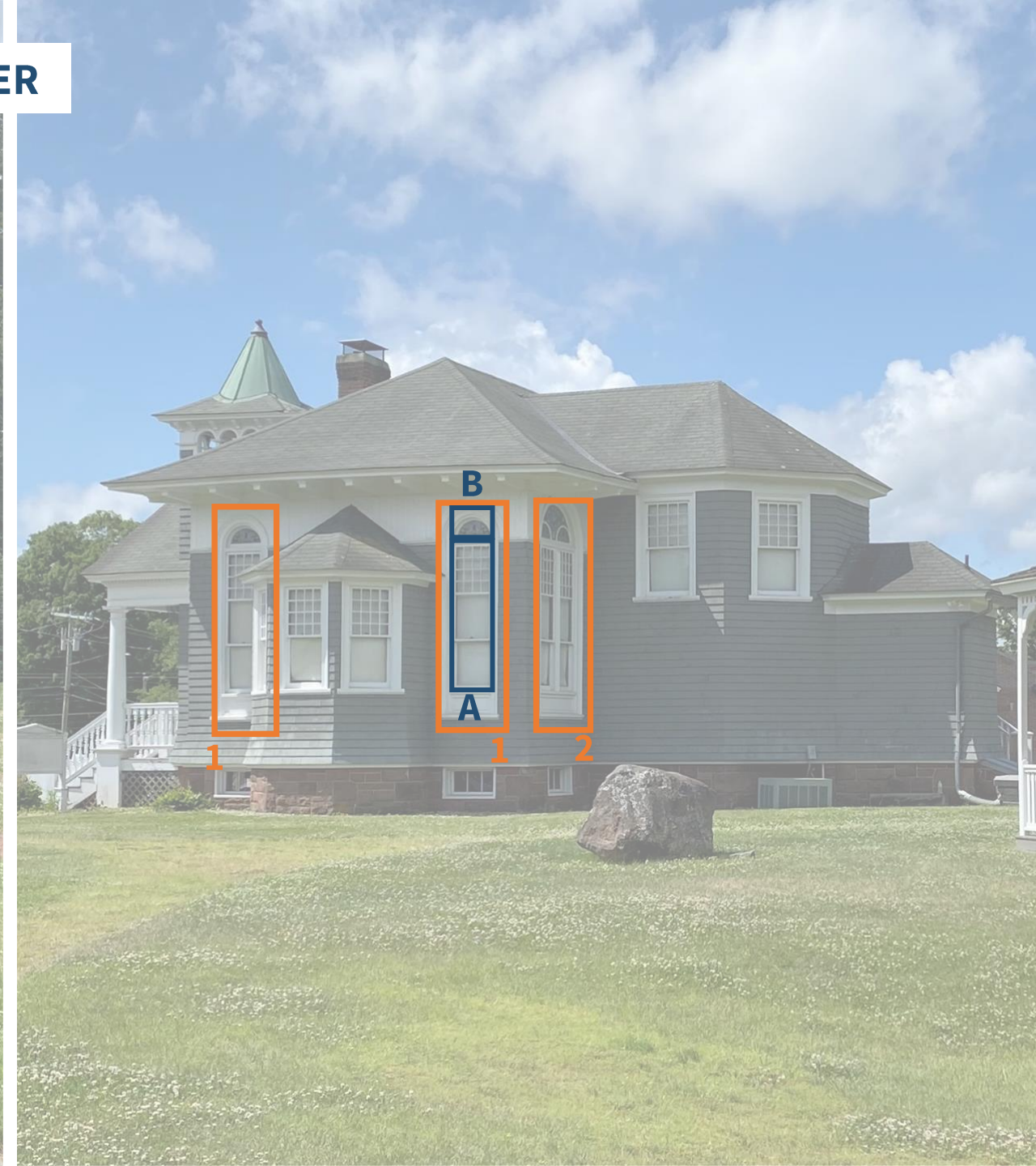

SITE CONTEXT: HISTORICAL MUSEUM & KIBBE FULLER



TOWN CONTEXT: CIVIC BUILDINGS



PROPOSED BUILDING MASSING – FRONT ENTRANCE



PROPOSED BUILDING MASSING – RELATING TO CONTEXT



TOP

MIDDLE

BASE

TOP

MIDDLE

BASE

PROPOSED BUILDING MASSING – RELATING TO CONTEXT



BACKGROUND

ENTRY

CANOPY

DOOR

FOREGROUND

PROPOSED BUILDING MASSING – RELATING TO CONTEXT



RENDERING – FRONT ENTRANCE



RENDERING – FRONT ENTRANCE



RENDERING – FROM BATTLE STREET



RENDERING – VIEW FROM KIBBE FULLER



RENDERING – VIEW FROM AMPHITHEATER



RENDERING – VIEW FROM AMPHITHEATER



SITE DIAGRAM: 200 PEOPLE

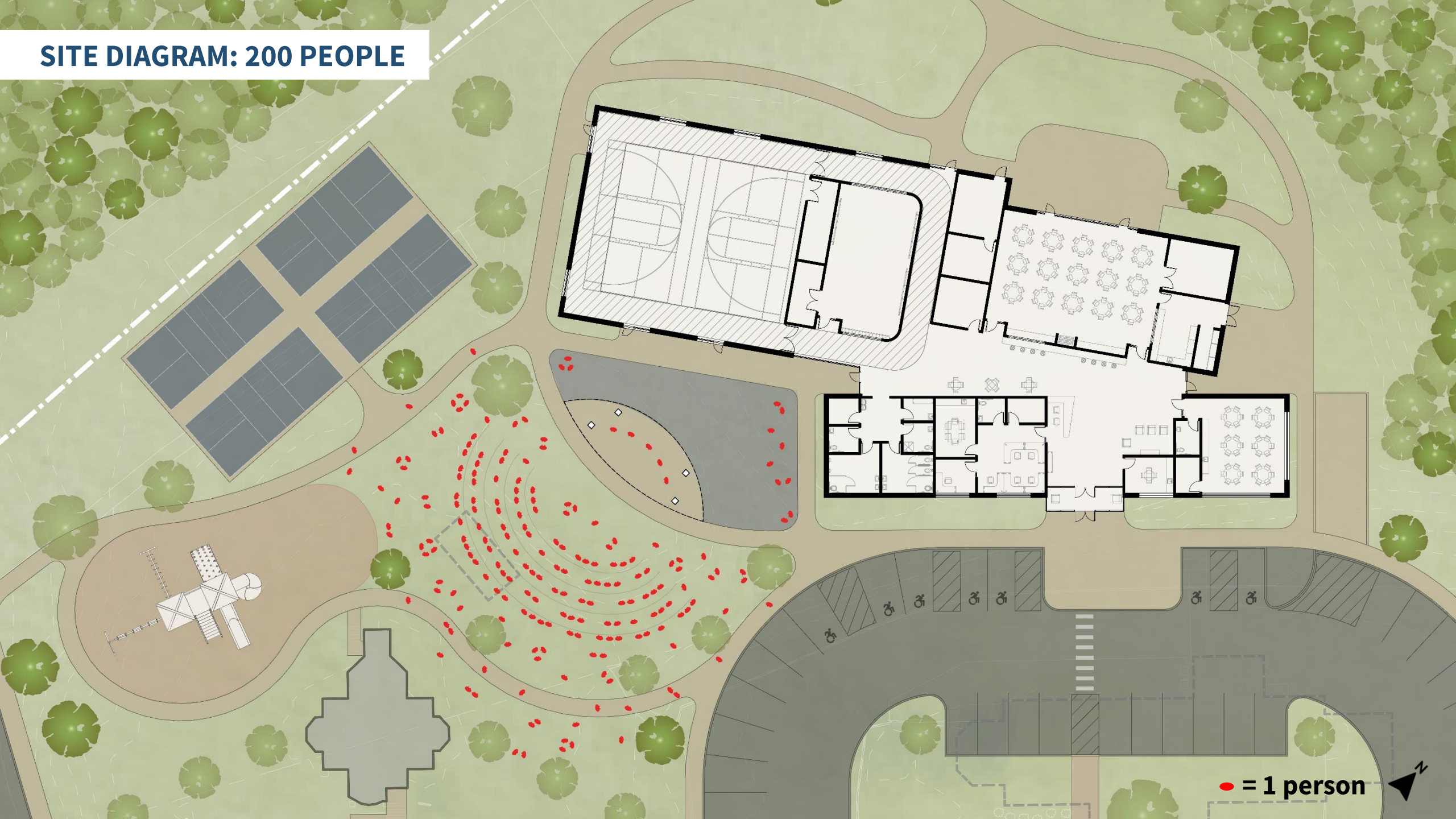

● = 1 person



SITE DIAGRAM: 300 PEOPLE

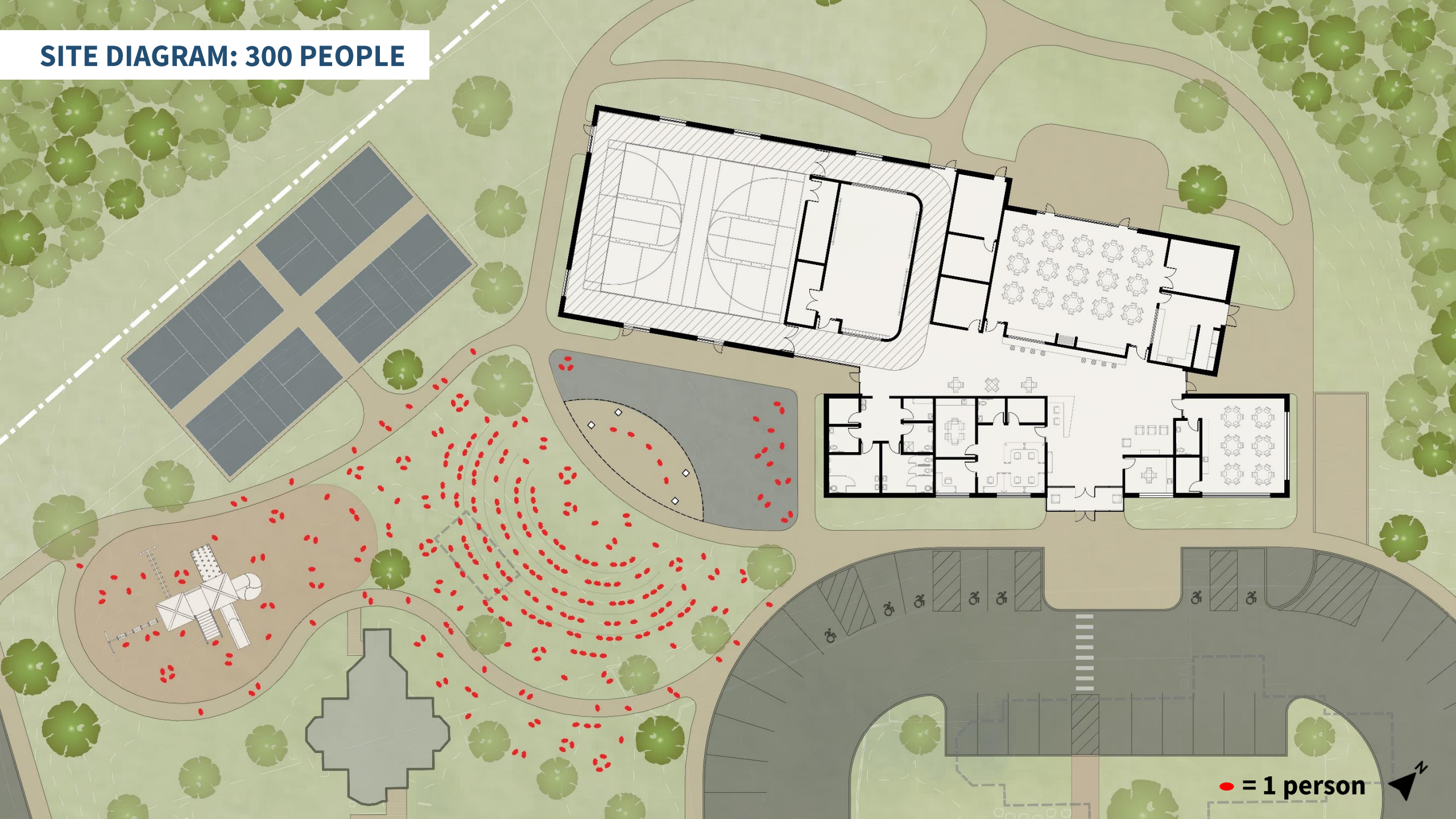

RENDERING – VIEW FROM PLAZA



RENDERING – MULTIPURPOSE ROOM PATIO



PROPOSED BUILDING MASSING – BIRDSEYE VIEW



PROPOSED BUILDING MASSING – BIRDSEYE VIEW



BUILDING INTERIOR – BIRDSEYE VIEW

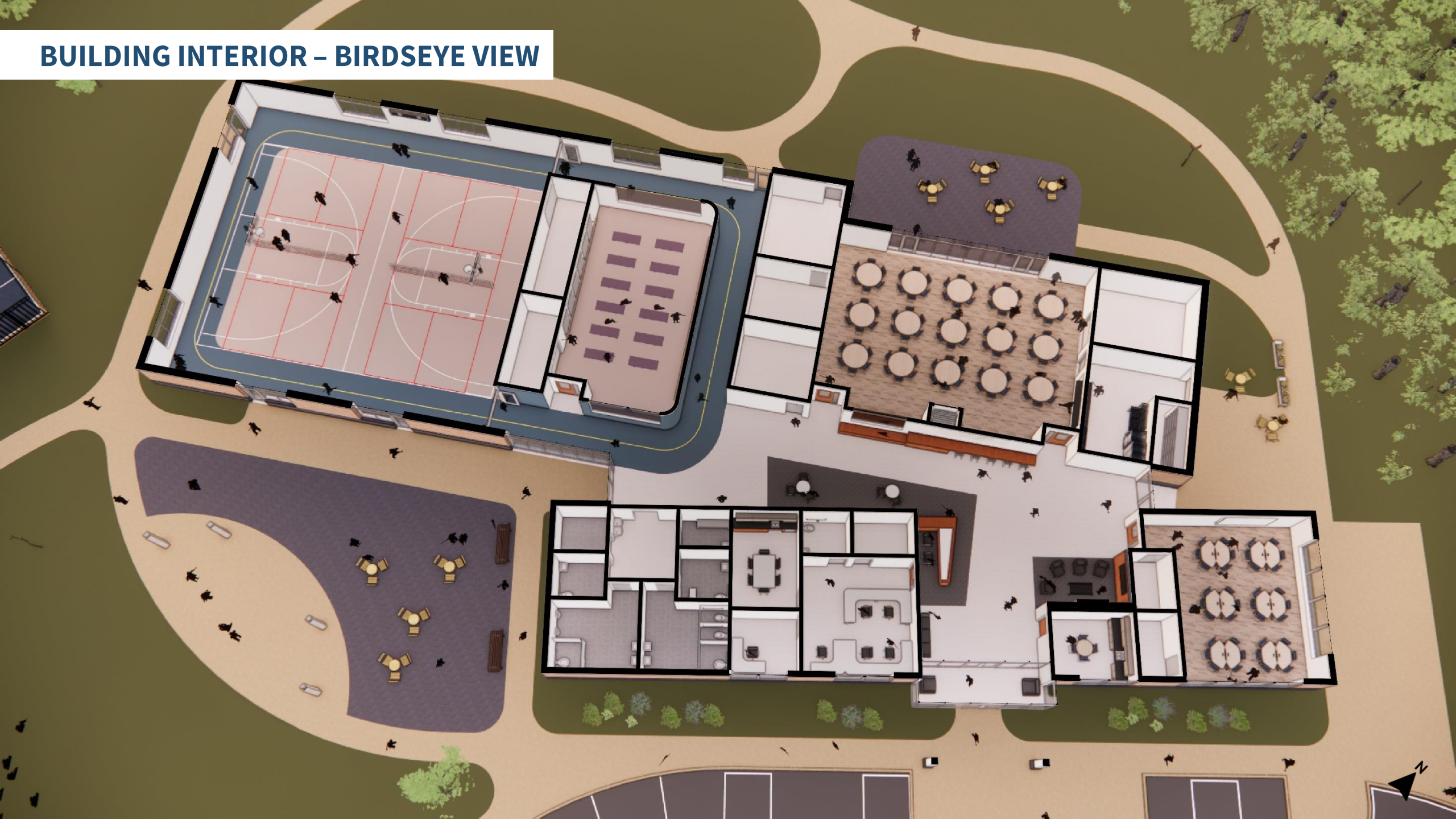

BUILDING INTERIOR – LOBBY & LOUNGE

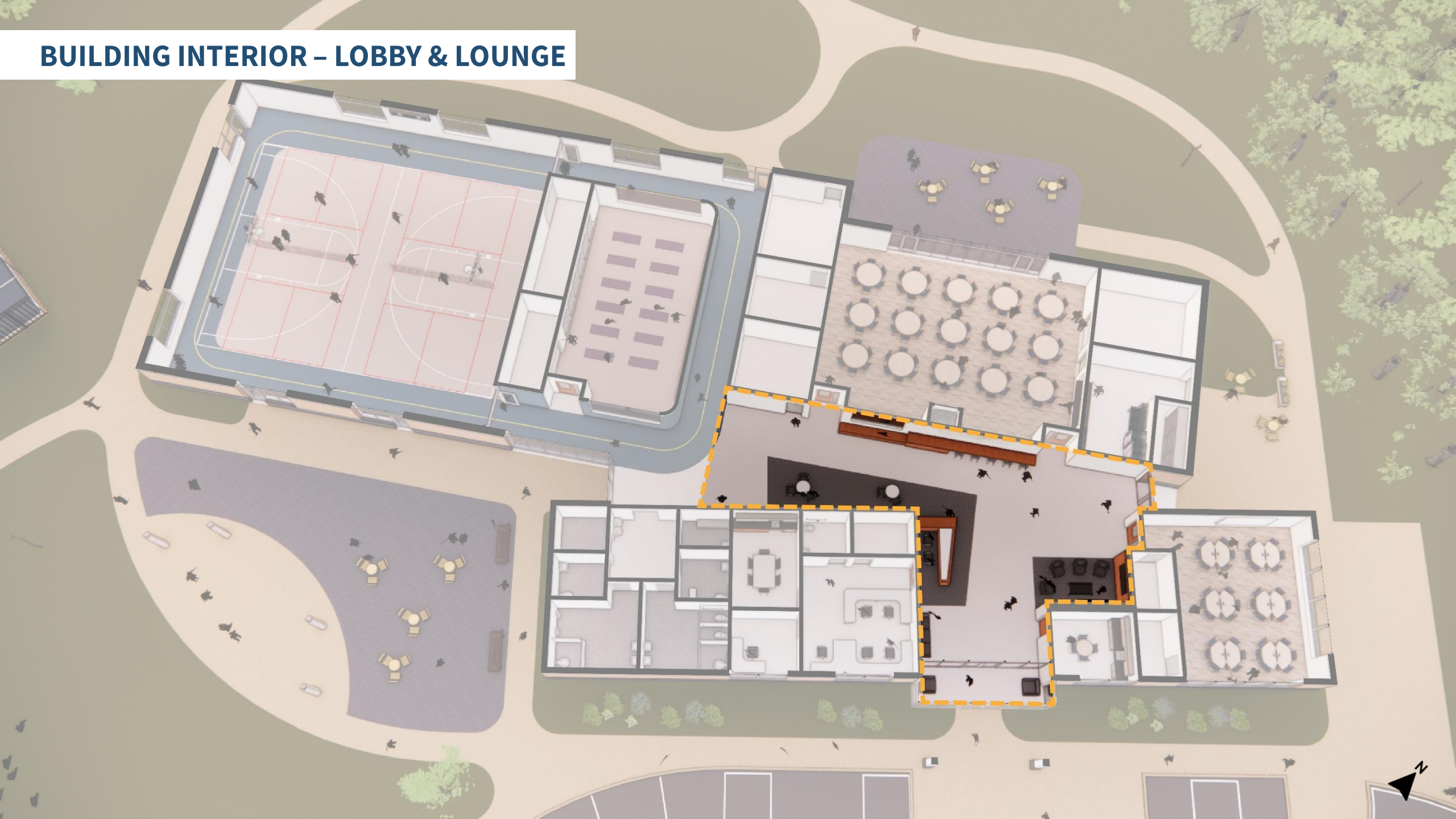

RENDERING – LOBBY



Somers
Senior / Community Center



RENDERING – LOBBY & LOUNGE



RENDERING – LOBBY & LOUNGE



RENDERING – LOBBY & LOUNGE



BUILDING INTERIOR – GYMNASIUM

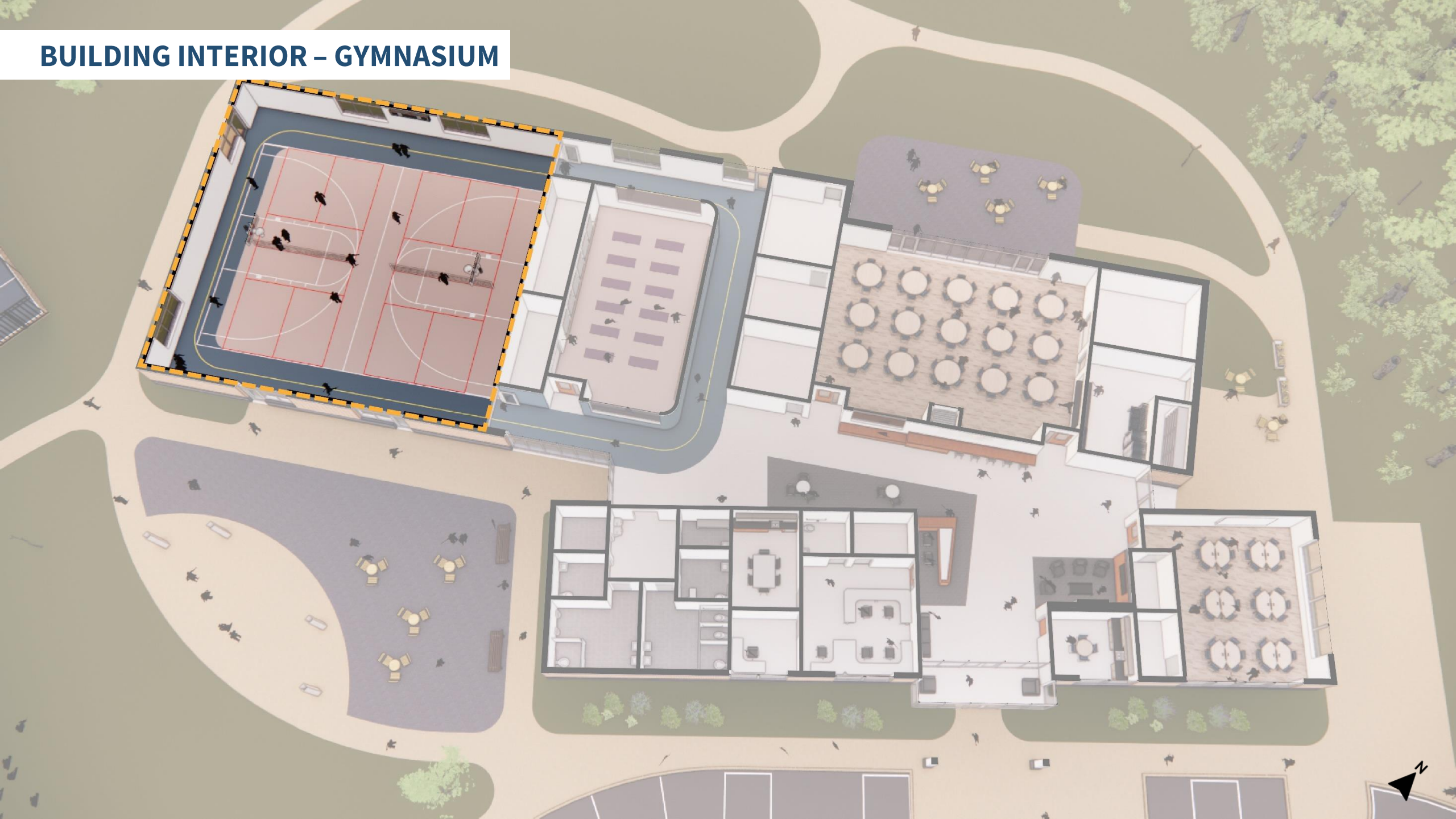

RENDERING - GYMNASIUM



RENDERING - GYMNASIUM



BUILDING INTERIOR – FITNESS STUDIO

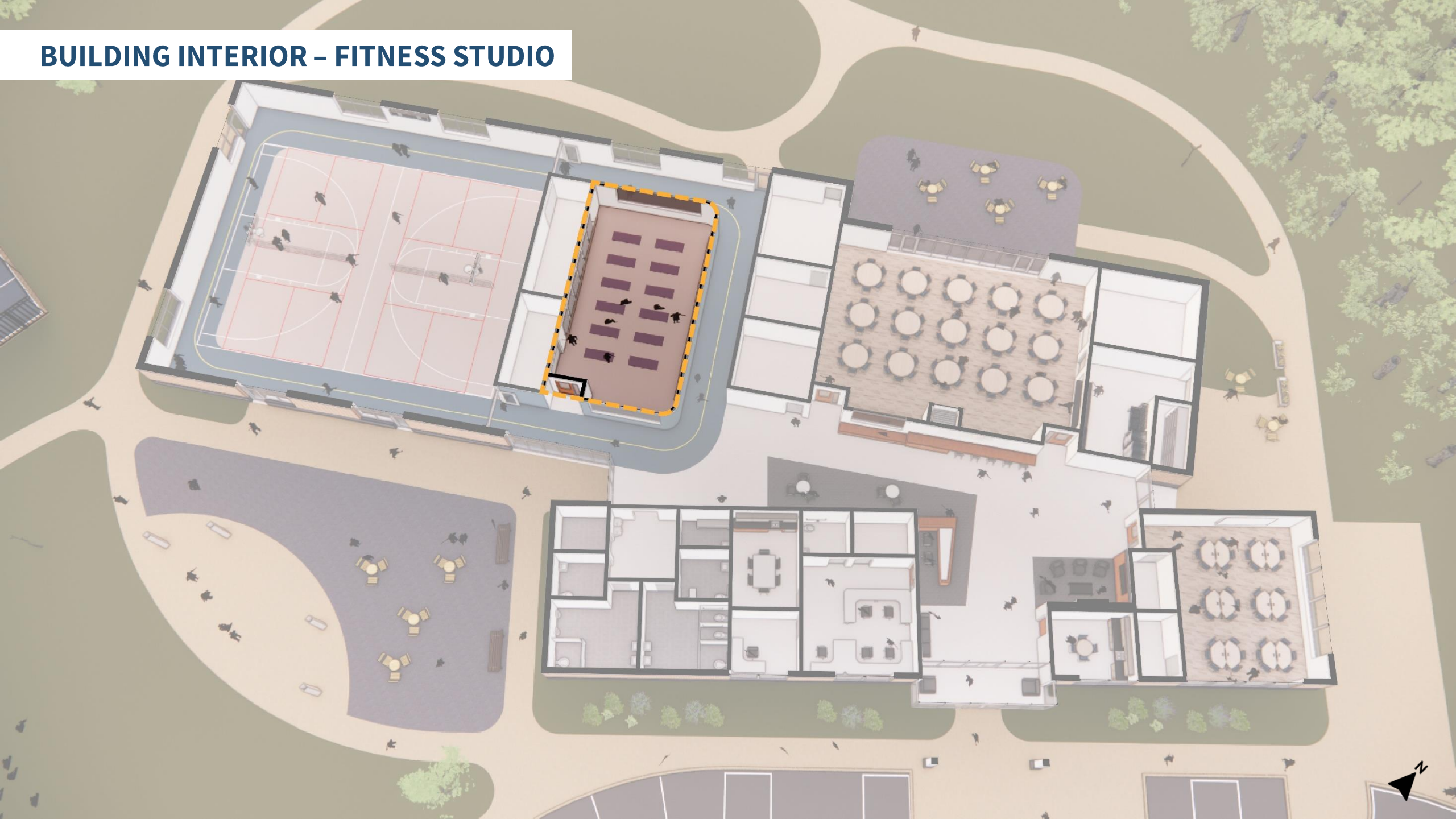

RENDERING – FITNESS ROOM



BUILDING INTERIOR – WALKING TRACK

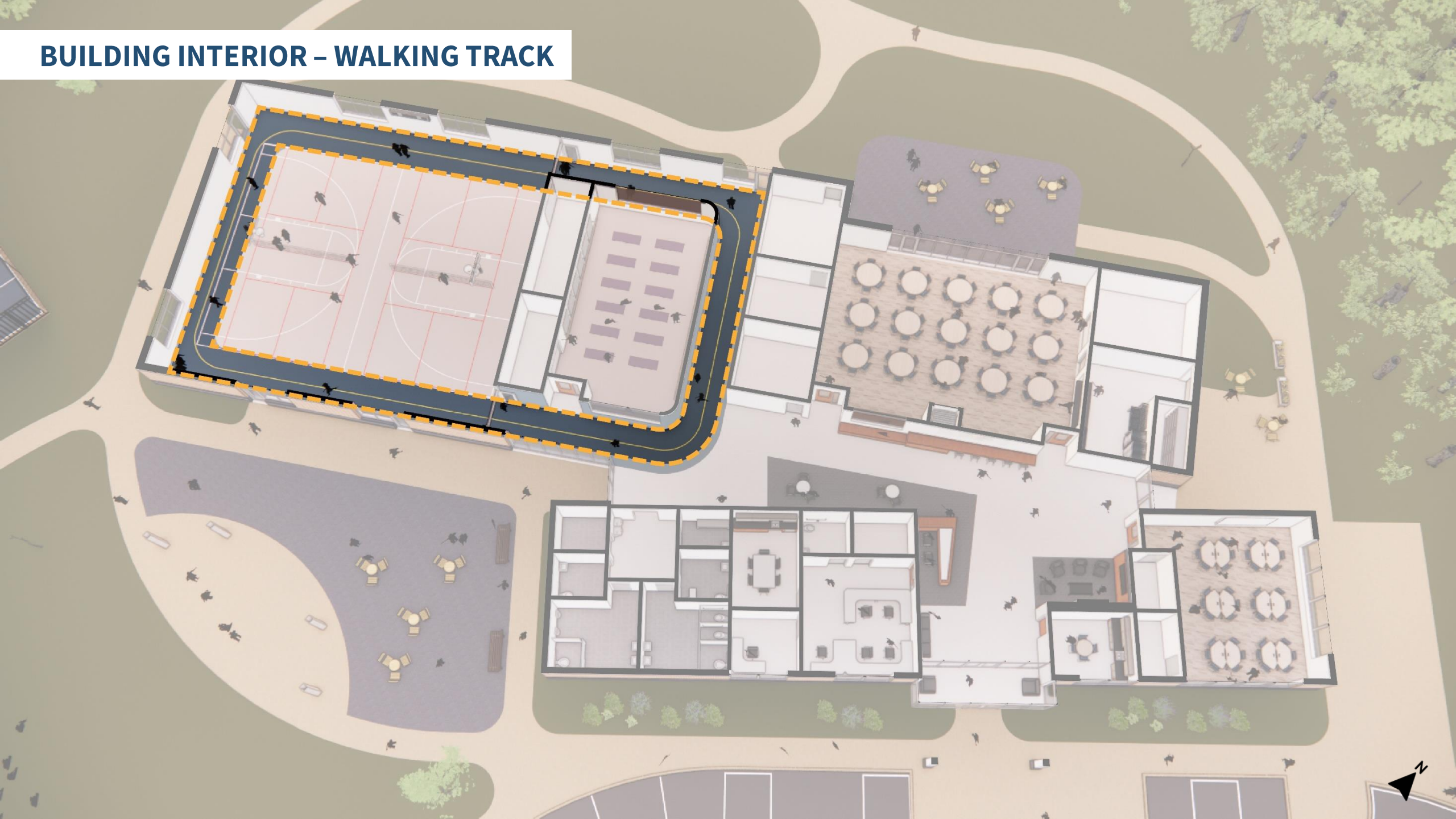

RENDERING – WALKING TRACK & LOUNGE



RENDERING – WALKING TRACK & LOUNGE



RENDERING – WALKING TRACK



BUILDING INTERIOR – MULTIPURPOSE ROOM

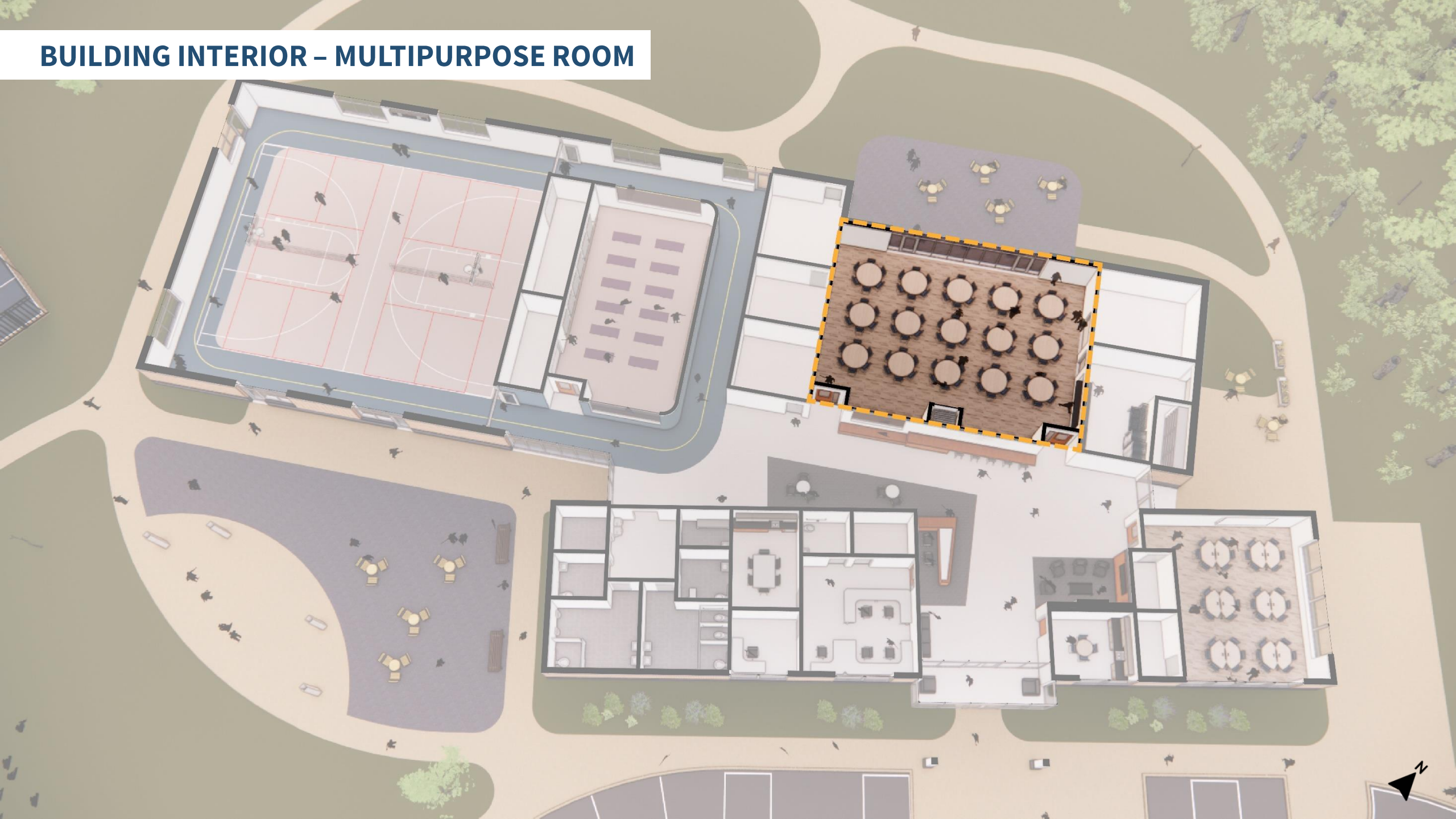

RENDERING – MULTIPURPOSE ROOM



BUILDING INTERIOR – CLASSROOM

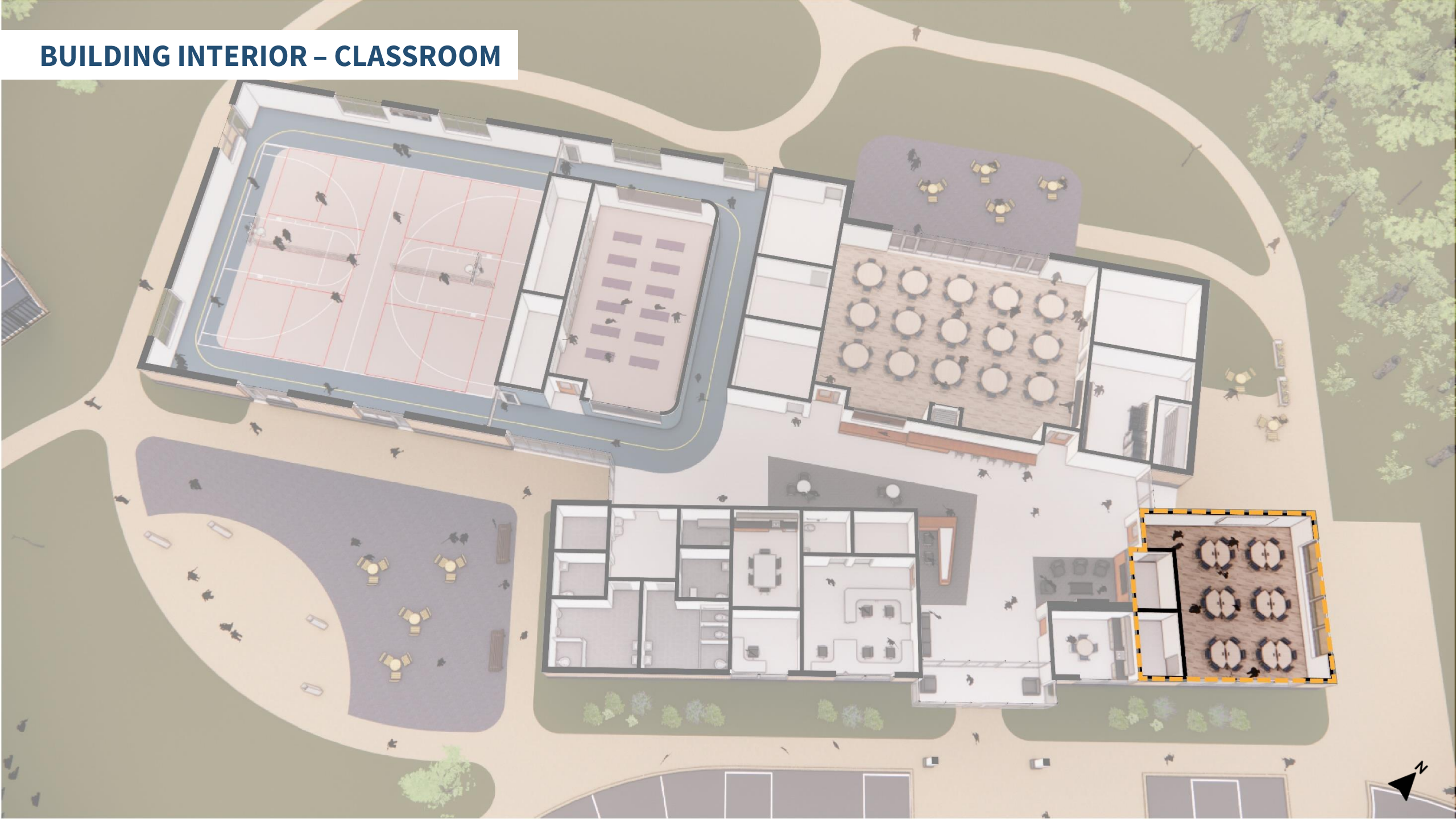

RENDERING – CLASSROOM



RENDERING – CLASSROOM



An aerial architectural rendering of a school campus. The central feature is a large, two-story brick building with a grey roof and a covered entrance. To the left of the building are four tennis courts with blue surfaces and black fencing. In the bottom left corner, there is a playground with colorful equipment. In the bottom center, there is a smaller, two-story house-like building with a grey roof. To the right of the main building is a large, paved parking lot with several cars parked. The entire campus is surrounded by lush green trees and grass. The word "QUESTIONS?" is overlaid in the center of the image in a bold, dark blue font.

QUESTIONS?